

CIRIL

EUBB20YGRIF

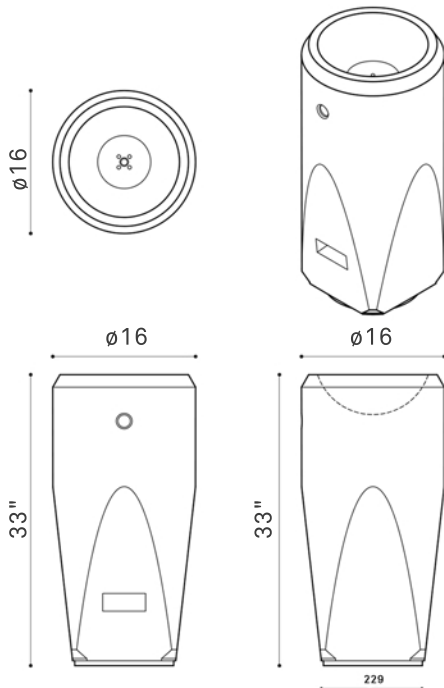

WEIGHT	451 lbs
DIMENSIONS	ø16 x 33"
FINISHES	SMOOTH, ACID WASH & LIGHT KEYSTONE TEXTURE.
COLORS	

CIRIL

The Ciril is the redesign of the first water fountain ever made by Durban in 1980s. It is the typical cylindrical water fountain, with a twist on the shape where the fountain meets the ground.

*The dimensions of the products shown on the webpage serve as an illustrative character and do not represent a contractual obligation of any kind. For more information, please do not hesitate to contact us. Copyright © 2020 Durban Precast. All rights reserved

