

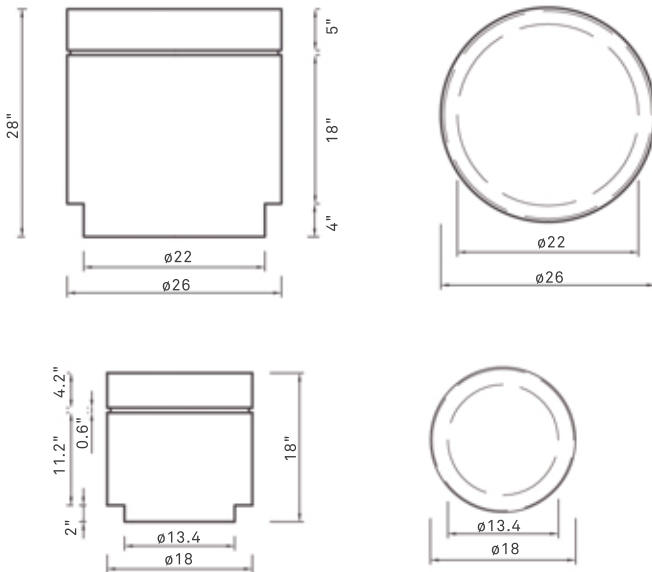

BUTTON SET



BUTTON SET

EUCJROSARIO



WEIGHT	large 1219 lbs small 346 lbs
DIMENSIONS	large $\varnothing 26 \times 28"$ small $\varnothing 18 \times 18"$
FINISHES	SMOOTH, ACID WASH & LIGHT KEYSTONE TEXTURE.
COLORS	

BUTTON SET

The Button Set is composed by reinforced concrete compact cylindrical designs. By combining the two sizes the design can generate individual seating areas or outdoor living-rooms.

*The dimensions of the products shown on the webpage serve as an illustrative character and do not represent a contractual obligation of any kind. For more information, please do not hesitate to contact us. Copyright © 2020 Durban Precast. All rights reserved

